

Contribution of CARE-PHIN to ILC design

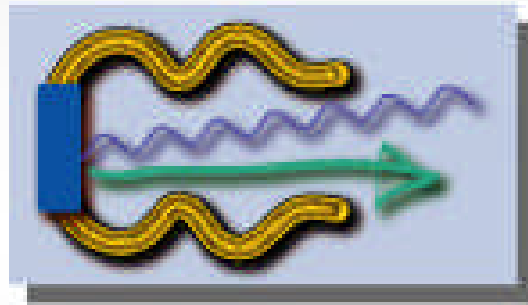

Andrea Ghigo on behalf of PHIN collaboration



ILC injector

- Normal conducting RF photoinjector for the production of unpolarized electron beam was developed for **TESLA** project
- Large experience has been gained running **TESLA Test Facility (TTF)**
- Improved emittance in **TTF SASE-FEL** project

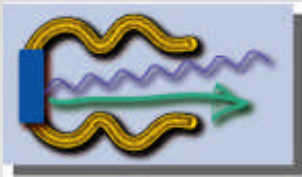

PHIN JRA main tasks

- ➡ **CTF3 Drive beam photo-injector**
- ➡ **Superconducting photo-injector for ELBE**
- ➡ **Plasma photo-injector**
- ➡ **R&D for high brightness photo-injectors:**
 - ❖ **Future colliders: CLIC and TESLA**
 - ❖ **FEL**
 - ❖ **etc,...**

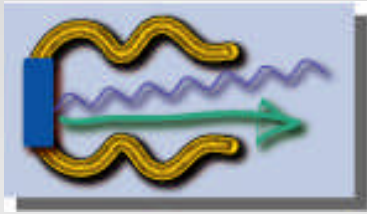

Institute	Acronym	Country	Coordinator	PHIN Scientific Contact	Associated to
CCLRC Rutheford Appleton Lab.	CCLRC-RAL	UK	P. Norton	J.G. Hirst	
CERN Geneva	CERN	CH	G. Guignard	G. Suberlucq	
CNRS-IN2P3 Orsay	CNRS-LAL	F	T. Garvey	G. Biennu	CNRS
CNRS Lab. Optique Appl. Palaiseau	CNRS-LOA	F	T. Garvey	V. Malka	CNRS
ForschungsZentrum ELBE	FZR-ELBE	D	J. Teichert	J. Teichert	
INFN-Lab. Nazionali di Frascati	INFN-LNF	I	S. Guiducci	A. Ghigo	INFN
INFN- Milan	INFN-MI	I	C. Pagani	I. Boscolo	INFN
Twente University- Enschede	TEU	NL	J.W.J. Verschuur	J.W.J. Verschuur	



University of Twente

RF gun photoinjector

1 - Electron current density production is more efficient in the photoemission process respect to the thermoionic one.

2 – The temporal structure of the electron bunch train is directly produced with the photoinjector laser pulses.

3 - Voltage on cathode, necessary to reduce the space charge and the electron shielding effects, is much higher in an RF gun (100MV/m) respect the DC one (200 kV/m).

Peak current from photoinjector is at least one order of magnitude higher than a thermoionic injector and the emittance is one order of magnitude lower.

PHIN \Leftrightarrow ILC related issues

International Linear Collider injectors requests are not so far from the parameters of the photoinjectors that PHIN JRA is studying and developing.

- Charge per bunch **2 – 3 nC**
- Number of bunches in macropulse **2000 - 3000**
- Macropulse repetition rate **(5 - 10 Hz)**
- time stability: RF gun – laser synchronization **(<1ps)**
- Charge stability along the train of bunches and pulse to pulse **(<0.2%)**





TESLA-500		
Accelerating gradient	E_{acc} [MV/m]	23.4
RF-frequency	f_{RF} [GHz]	1.3
Fill factor		0.747
Total site length	L_{tot} [km]	33
Active length	[km]	21.8
No. of accelerator structures		21024
No. of klystrons		584
Klystron peak power	[MW]	9.5
Repetition rate	f_{rep} [Hz]	5 
Beam pulse length	T_p [μ s]	950 
RF-pulse length	T_{RF} [μ s]	1370
No. of bunches per pulse	n_b	2820 
Bunch spacing	Δt_b [ns]	337
Charge per bunch	N_e [10^{10}]	2 
Emittance at IP	$\gamma \varepsilon_{x,y}$ [10^{-6} m]	10, 0.03
Beta at IP	$\beta_{x,y}^*$ [mm]	15, 0.4
Beam size at IP	$\sigma_{x,y}^*$ [nm]	553, 5
Bunch length at IP	σ_z [mm]	0.3
Beamstrahlung	δ_E [%]	3.2
Luminosity	$L_{e^+e^-}$ [10^{34} cm $^{-2}$ s $^{-1}$]	3.4
Power per beam	$P_b/2$ [MW]	11.3
Two-linac primary electric power (main linac RF and cryogenic systems)	P_{AC} [MW]	97
<hr/> <i>e⁻e⁻ collision mode:</i> <hr/>		
Beamstrahlung	δ_{E,e^+e^-} [%]	2.0
Luminosity	$L_{e^+e^-}$ [10^{34} cm $^{-2}$ s $^{-1}$]	0.47

Table 1.3.1: TESLA parameters for the $E_{cm} = 500$ GeV baseline design. The machine length includes a 2% overhead for energy management. The klystron power and primary electric power quoted include a 10% regulation reserve.

CTF3 Drive Beam Parameters

	Unit	CTF3
Pulse charge	nC	2.33 ←
Pulse width (FWHH)	ps	10
Peak current	A	240
Number of pulses	-	2310 ←
Distance between pulses	ns	0,46
Charge stability	%	± 0.1
Train duration	mS	1.54 ←
Train charge	mC	5.04
Repetition rate	Hz	5 ←
Minimum <i>QE</i>	%	1.05
Minimum lifetime at <i>QE</i> _{min}	h	100

PHIN contributions to ILC project

Significative contribution can come from experience exchanges between PHIN-JRA, TTF project and ILC injector study group in following items:

- Photocathode material studies (CERN, Twente Un.)
- High power laser: diode pumped multipass amplifiers (CCLRC, CNRS-LOA)
- NC / SC RF gun structure (CNRS-LAL, FZR, CERN)
- RF \Leftrightarrow laser synchronization (CERN, INFN)
- Longitudinal and transverse laser pulse shaping (INFN, LOA)

Laser for CTF3

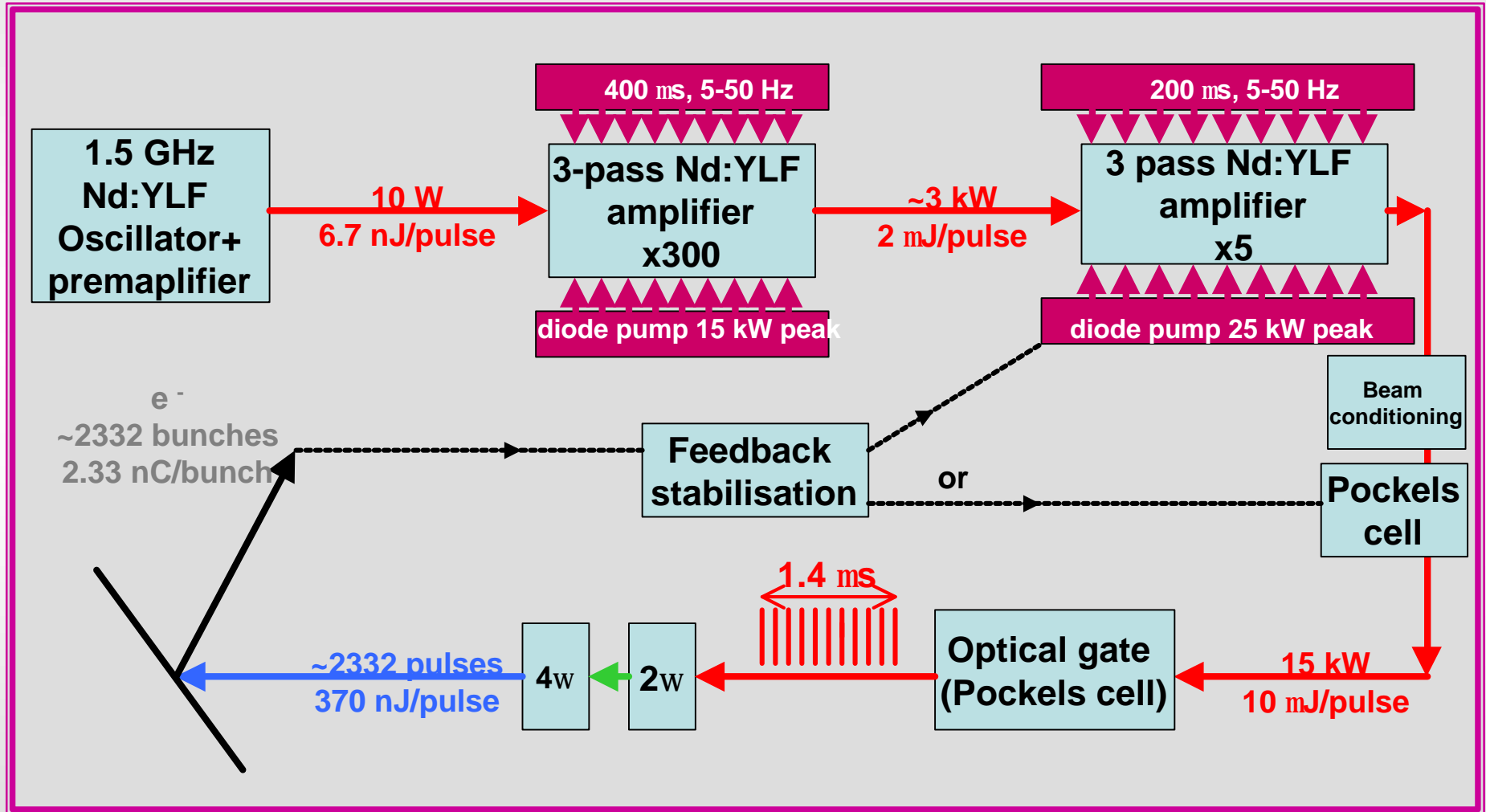

Normal-conducting cathode inside SC cavity

Cavity: Niobium 3+½ cell (TESLA Geometry)
Choke filter

Operation: T = 1.8 K

Frequency: 1.3 GHz

HF power: 10 kW

Electron energy: 10 MeV

Average current: 1 mA

Cathode: Cs₂Te
thermally insulated,
LN₂ cooled

Laser: 262 nm, 1W

Pulse frequency: 13 MHz & < 1 MHz

Bunch charge: 77 pC & 1 nC

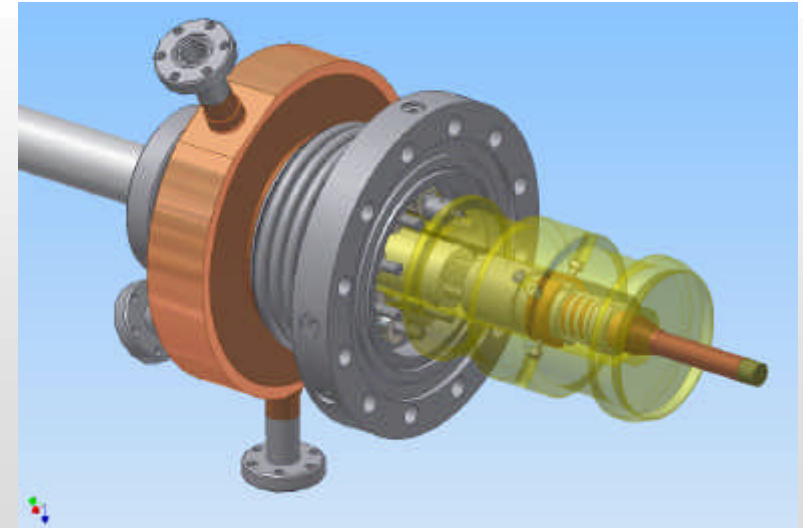
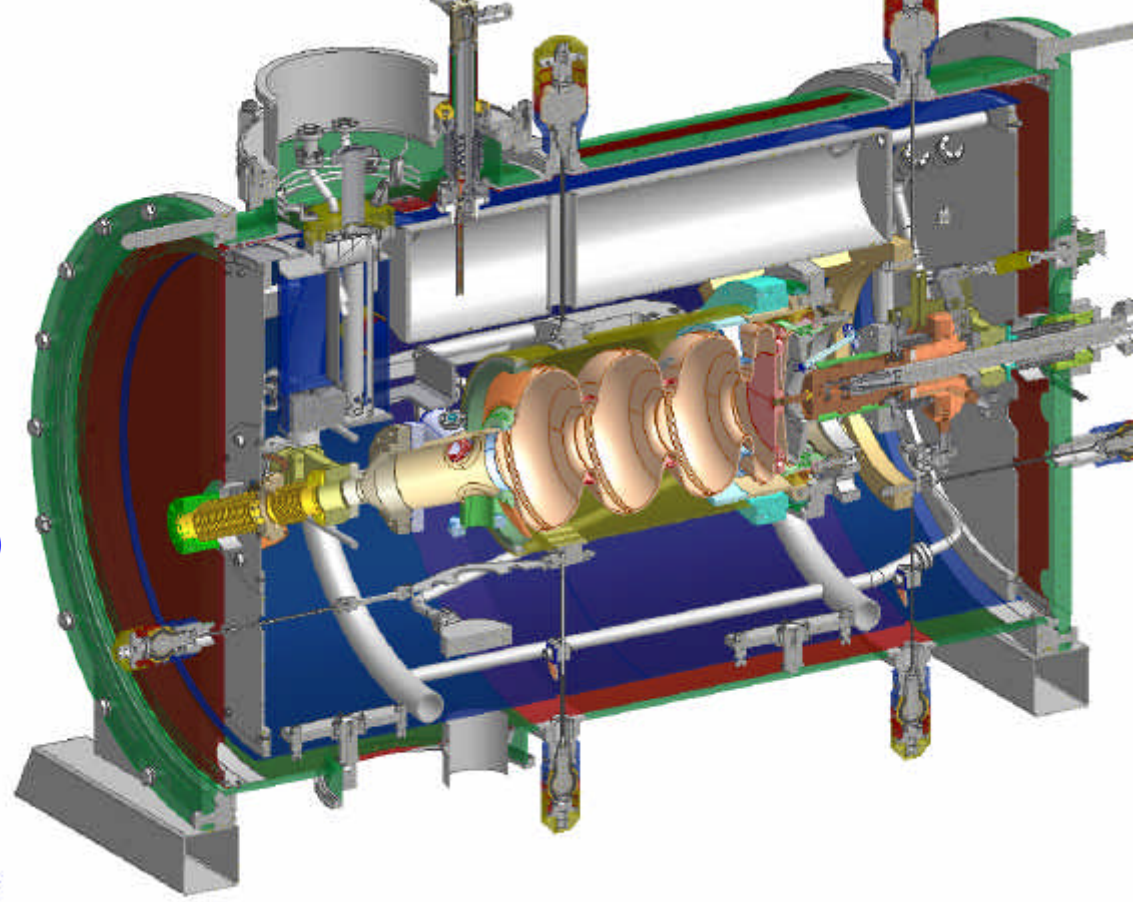

Laser pulse shaping

Collinear Acousto-Optic modulator (AOM) “Dazzler”

Flat top pulse:

- 10 ps,
- rise time <0.8ps
- ripples < 20%.

The Dazzler is able to produce arbitrary and very reproducible temporal profiles

