

French Funding Agencies

- **CNRS/IN2P3** : National research Institute on Nuclear Physics and Particle Physics
 - LAL-Orsay
 - IPNO-Orsay
 - LAPP-Annecy
- **CEA/DSM** : fundamental matter research within Atomic Energy Commission
 - DAPNIA-Saclay
- **CNRS** : LOA, Applied Optics Laboratory

French Effort on CARE/SRF (2004-2007)

WP1 Coordination : LAL (8 h·m)

WP5 Electropolishing : DAPNIA (85 h·m)

WP7 Couplers : LAL (258 h·m)

WP8 Tuning systems : DAPNIA (16 h·m), IPNO (24 h·m)

WP10 CRYHOLAB tests: DAPNIA (66 h·m), IPNO+LAL (36 h·m)

WP11 Beam position monitor : DAPNIA (58 h·m)

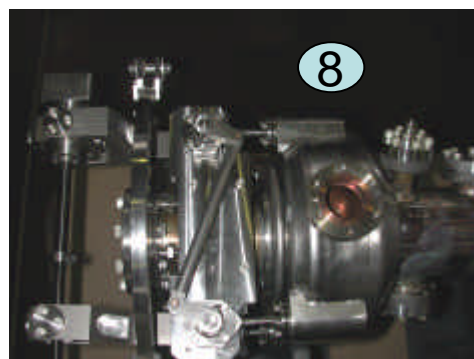

11

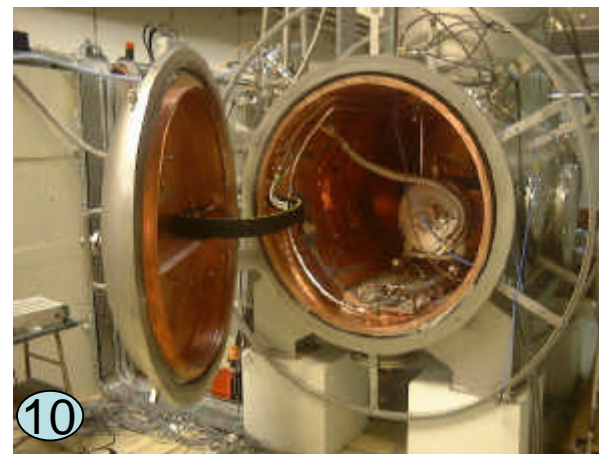
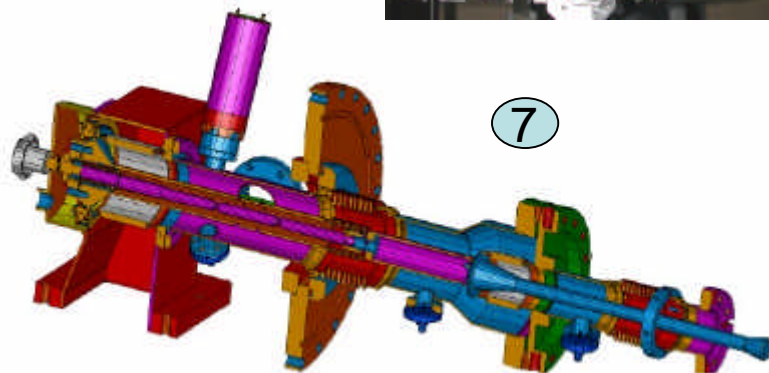

French Effort on CARE/PHIN (2004-2007)

- WP1** Coordination : LAL-Orsay (3 h·m)
- WP2** Photo cathode : LAL-Orsay (32 h·m), LOA (60 h·m)
- WP3** LASER : LAL-Orsay (51 h·m)
- WP4** Gun : LAL-Orsay (207 h·m), LOA (78 h·m)

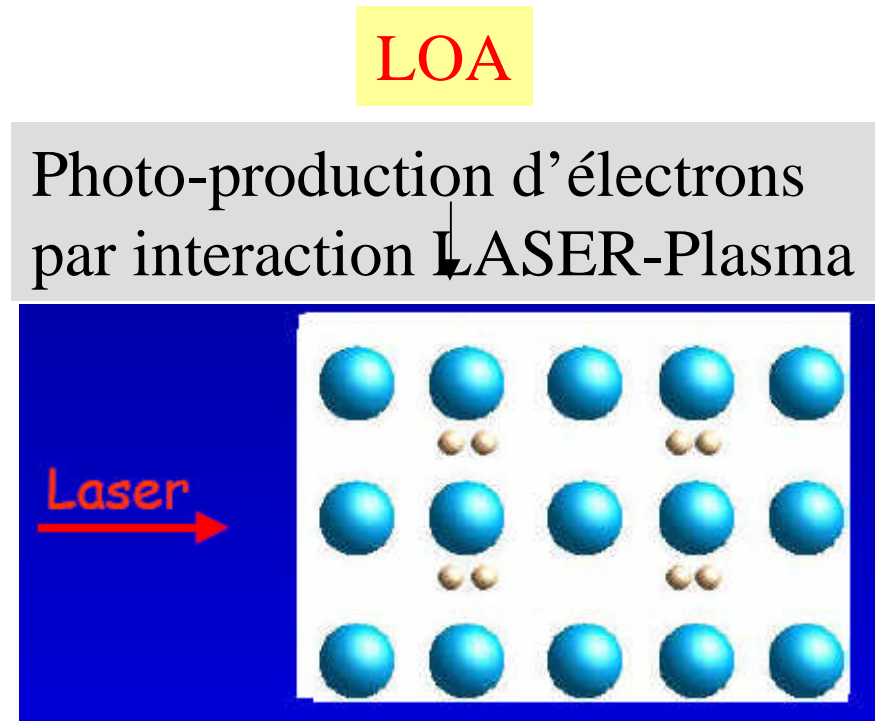
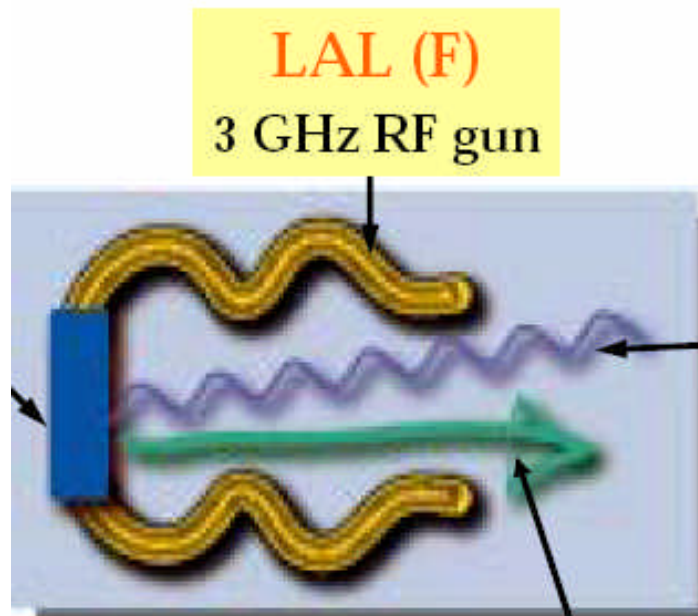

French Effort on *EUROTeV* (2005-2007)

- WP1 Coordination : LAPP (6 h·m)
- WP2 Optique BDS + Quadripôle Nb3Sn : DAPNIA (73 h·m)
- WP5 Polarimetry : LAL (156 h·m)
- WP6 Machine-detector Interface : LAL (96 h·m)
- WP7 Alignment and stabilisation : LAPP (144 h·m)

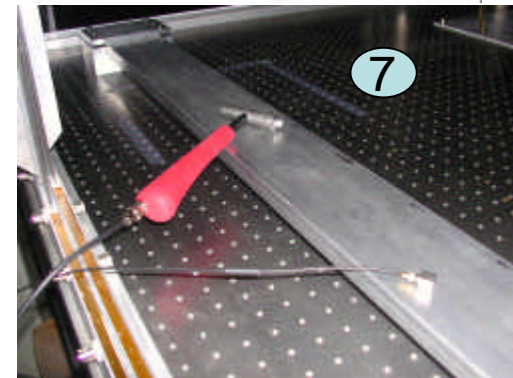
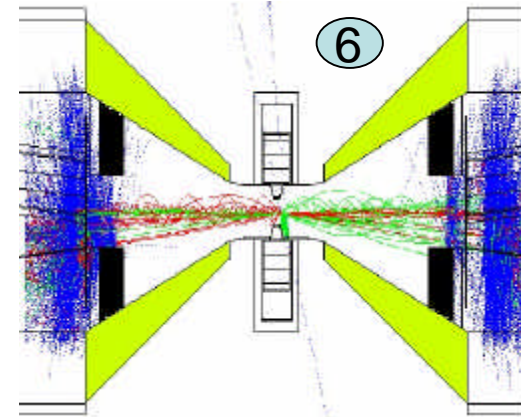
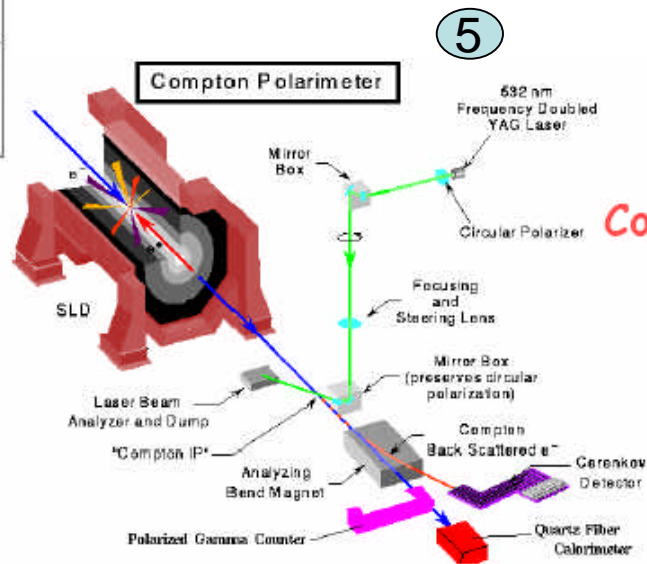
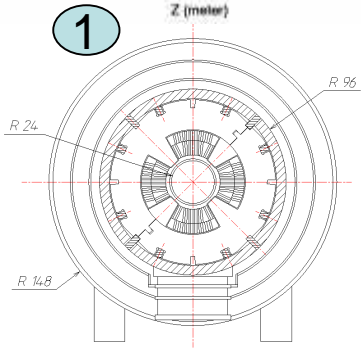
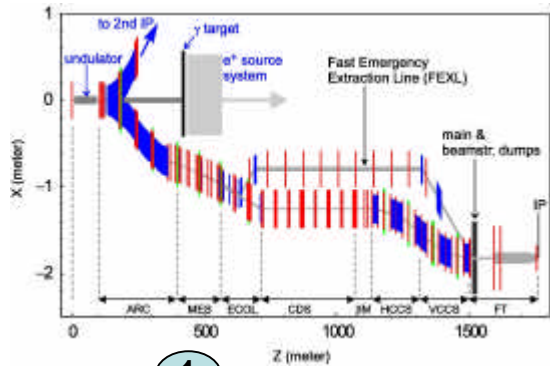

French Effort on TTF2

- Machine Protection Electronics : 2 engineers (DAPNIA)

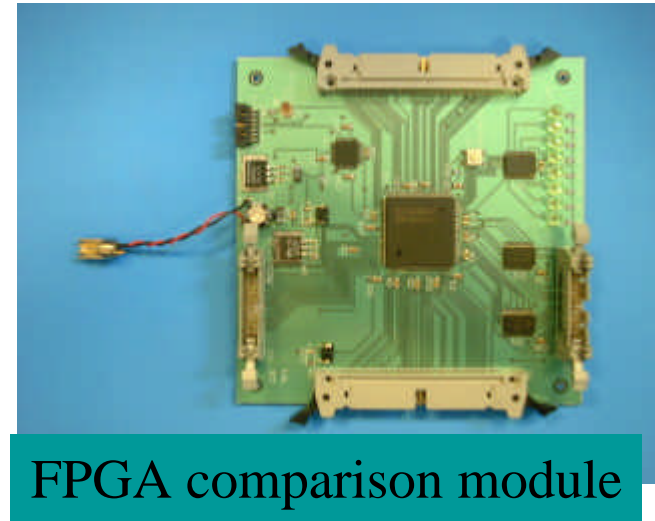
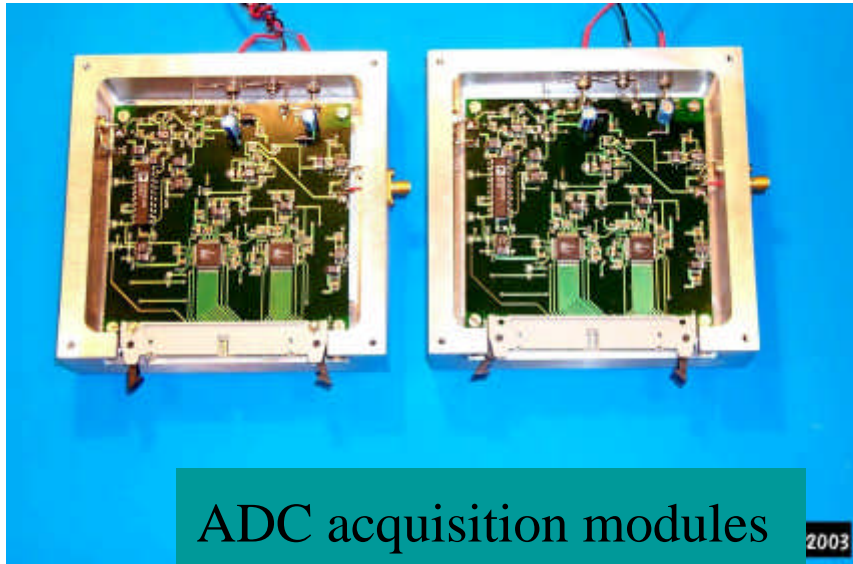

- HOM studies:

1 Engineer +

1 PhD (DAPNIA+DESY)

Dipole modes allow one to center the beam to $50\ \mu\text{m}$ in RF cavities

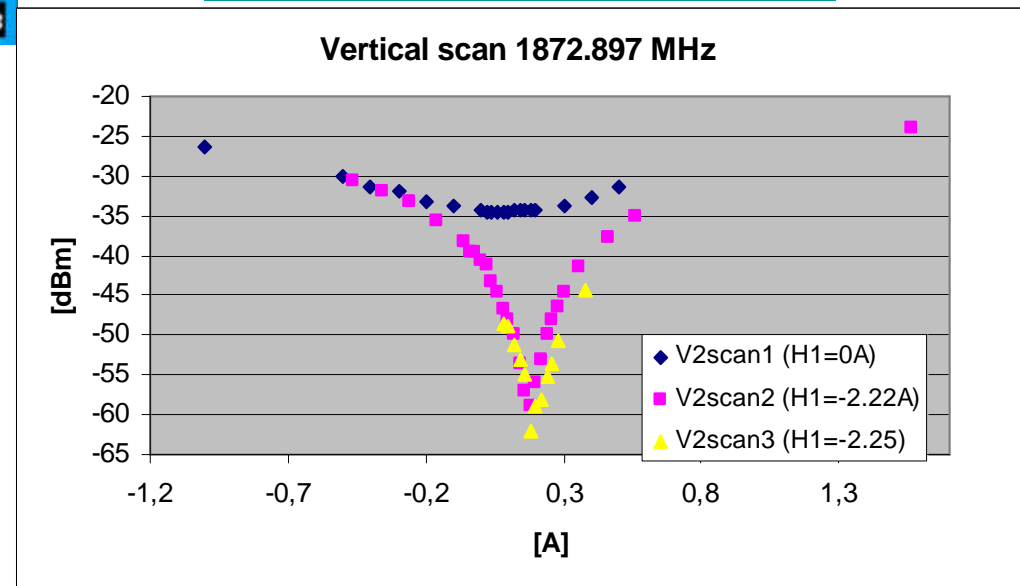

+ Contribution on Couplers : LAL-Orsay

- Coupler prototypes studies :
15 m·y in CARE/SRF + 10 m·y DESY-LAL
- Industrialization of Couplers
8 m·y in XFEL

- + Contribution on RF technology
- Horizontal Test Cryostat CRYHOLAB
IPNO + LAL + Saclay

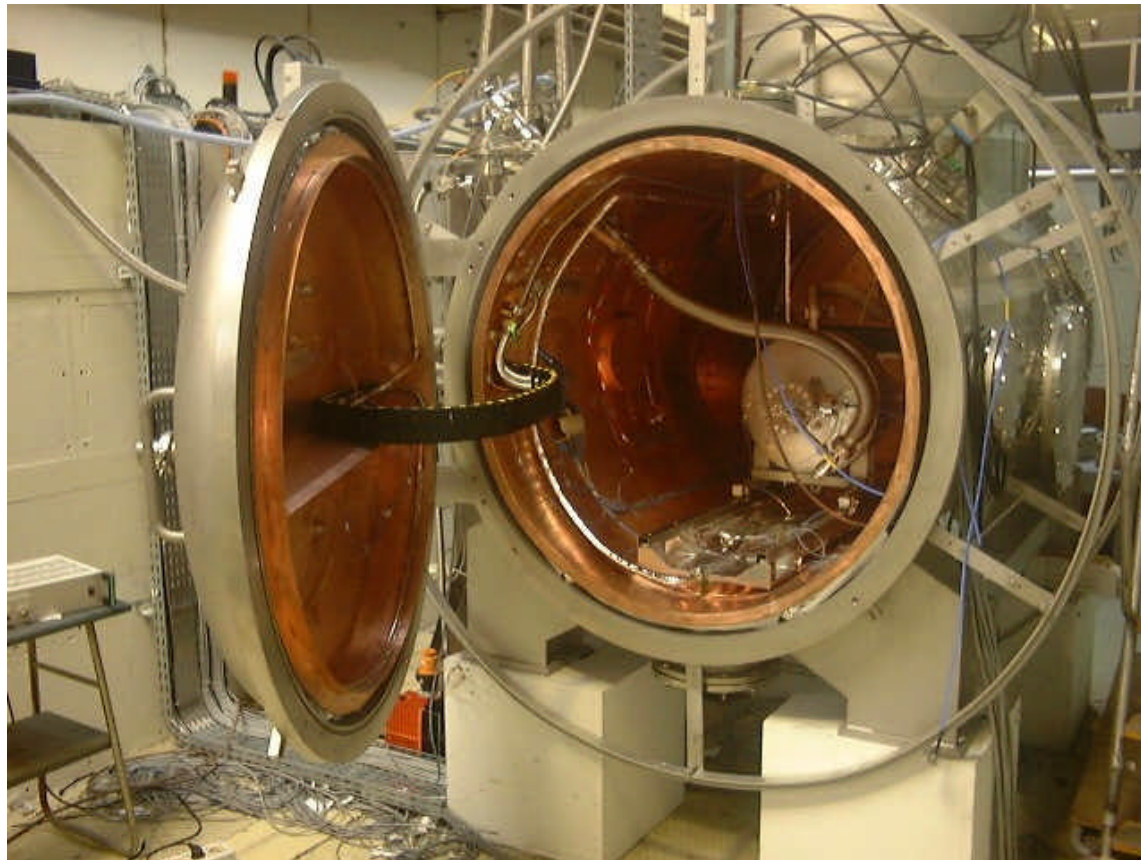

+ Contribution to high gradient cavity R&D : Saclay

- RF dissipation at high gradient (fast baking, oxide-Nb interface, ...) 5 m·y
- Quench studies (surface morphology, grain boundaries) in collaboration with Uni. Wisconsin Madison + P. Bauer 1 m·y/y

+ Contribution to BDS-MDI

- Detector solenoid studies (CMS or US-like)
 Saclay: 1 m·y for CDR + ? m·y for TDR
- Nb3Sn quadrupole prototype (1 meter)
 Saclay : ???
- Gamma-gamma collision by backscattering
 LAL-Orsay : 8 m·y

+ Contribution to Reliability studies : IPN Orsay

- Synergy between reliability studies between XADS and ILC 4 m.y